

Owner's Manual — Phoenix FireBird TX 80

Installation, Operation & Service Instructions

Read and Save These Instructions

Phoenix's new hydronic fan coils, the Phoenix FireBird TX 80 and TX 200 set a new standard for heat drying technology. The Phoenix FireBird fan coils, when coupled to a glycol central heat system, deliver safe, efficient, and even heat to your restoration job.

The Phoenix FireBird TX 80 provides 80,000 BTU/hr and 950 CFM. The Phoenix FireBird hydronic fan coils are engineered to be the most efficient, most rugged, and most portable hydronic heat exchangers made.

Unlike direct-fired heaters, Phoenix FireBird fan coils completely isolate the heat source from combustion byproducts. This not only provides a safer heat source on the job, but also eliminates the need for outside air ventilation. By doing so, the Phoenix FireBird hydronic fan coils give restoration professionals higher efficiency, more flexibility in job setup, and a larger number of drying opportunities.

Phoenix FireBird fan coils are thermostatically controlled, allowing the user to set the optimal temperature for each job. Both units use a motorized impeller and high efficiency coil to ensure the most efficient heat transfer and even heat distribution throughout the structure.

The Phoenix FireBird TX 80, like the TX 200, can be transported and operated upright or on its back. This flexibility, along with multiple ducting options, allows the restoration professional to maneuver into tight or low-clearance spaces and direct the heat precisely where it is needed.

The Phoenix FireBird fan coils feature compact designs, sturdy handles, and chamfered cabinets. Their light weight, large recessed wheels, and high-impact skid plates help negotiate curbs and stairs easily. The units' balanced designs and integral lift hooks further enhance maneuverability on the job site, while stainless steel cabinets ensure years of service without corrosion or the need for repainting.

The Phoenix FireBird TX 80 Hydronic Heat Exchanger

- 80,000 BTUs
- 950 CFM
- ETL Certified to ANSI/UL 1995 and CSA C22.2 No. 236
- Thermostatically controlled
- Multiple air filter options
- Multiple ducting options
16" intake, 14" supply
- Stainless steel cabinet
- Operates both vertically and horizontally



Specifications subject to change without notice.

TS-745

02/12

Table of Contents

Safety Precautions	2
1. Specifications	3
2. Operation	
2.1 Transporting.....	3
2.2 Electrical Requirements	3
2.3 Power Switch.....	3
2.4 Glycol Connections	3
2.5 Ducting	3
3. Maintenance	
3.1 Air Filter	3
4. Service	
4.1 Technical Description	4
4.2 Troubleshooting	4
5. Options and Accessories.....	4
6. Wiring Diagram	4
7. Service Parts	5
8. Warranty.....	6
9. Glycol MSDS	7

Serial No. _____

Purchase Date _____

Dealer's Name _____

Read the installation, operation and maintenance instructions carefully before installing and operating this device. Proper adherence to these instructions is essential to obtain maximum benefit from your Phoenix FireBird TX 80.

WARNING

Unit Intended for INDOOR USE ONLY; DO NOT USE OUTDOORS

- Device is HOT when in use. To prevent burns, avoid skin contact with hot surfaces.
- Use handle when moving device.
- Extreme caution is necessary when device is used by or near children or invalids and whenever device is left operating unattended.
- Always unplug unit when not in use.

- DO NOT OPERATE with damaged cord, inlet receptacle, or after unit malfunctions, has been dropped or damaged in any manner. Return to authorized service facility for adjustment or repair.
- Device not intended for use directly in an area where it may fall into a bathtub or other water container.
- DO NOT run cord under carpeting or other floor covering. Arrange cord away from traffic area and where it will not present a trip hazard.
- To disconnect device, turn controls off, then remove user-supplied cord from inlet receptacle.
- Connect ONLY to properly grounded outlets.
- DO NOT insert or allow foreign objects to enter any inlet or supply openings as this may cause an ELECTRIC SHOCK or FIRE, or damage to the heater.
- To prevent a possible fire, do not block air inlet or supply openings in any manner. Do not use on soft surfaces, like a bed, where openings may become blocked.
- Device is not explosion proof. Do not use in areas where gasoline, paint, or flammable liquids are used or stored.
- Use device only as described in this manual. Any other use not recommended by the manufacturer may cause fire, electric shock, or injury to persons.
- Ensure that the user-supplied cord is sized appropriately to the current of this device.

1. Specifications

Part Number: 4029410
Power: 1.8 full load amps, 120 V / 60Hz
Blower: 950 CFM

Temperature

Set Point Range: 40°F to 180°F

Filter Box

(Option): Filter Size: 16" X 16" X 2"

Hydronic

Connections: 3/4" ISO 7241 Series B couplings

Duct

Connections: Inlet: 16" Flex-Duct
Supply: 14" Lay Flat-Duct

Warranty:

1 Year Parts and Labor

Dimensions:

	Unit	Shipping
Width	20.25"	24"
Height	40"	45.25"
Depth	21.375"	25.5"
Weight	85 lb	110 lb

2. Operation

2.1 Transporting

The Phoenix FireBird TX 80 may be transported and operated upright or on its back. The unit features a high-impact plastic skid plate which protects the unit while navigating obstacles such as curbs, stairways, and while loading into vehicles.

2.2 Electrical Requirements

The Phoenix FireBird TX 80 requires 120VAC and features a standard 120VAC inlet receptacle with ground. When properly connected to a grounded outlet, it provides a ground connection through the user-supplied cord in order to protect the operator from electric shock. Ensure that the supply cord used is a 2-conductor with ground and that it has no nicks or cuts in the insulation. The electrical inlet is designed to accept a NEMA 5-15R (receptacle - 15 amp, 2 pole + ground).

2.3 Power Switch and Thermostat

Master POWER Switch: The master power switch located on the side of the Phoenix FireBird TX 80 can be used to turn the unit ON, OFF.

When set to ON, the Phoenix FireBird TX 80 will energize the blower. Temperature set point can be set by using a flat-bladed screwdriver. The thermostat will control only the blower motor - not the glycol fluid - so the unit may be hot even when the blower is not energized. The blower will cycle on and off as needed to maintain the selected temperature.

2.4 Glycol Line Connections

Hydronic (hot water/propylene glycol) connections are made using 3/4 inch couplings that comply with the ISO 7241 Series B standard. These couplers minimize the fluid loss on disconnection - but there is a small amount lost (~1 tablespoon/16cc). The Phoenix FireBird TX 80 has been designed to direct this loss away from the fan inlet.

Ensure that the hydronic pump is off before attempting connection of the hydronic couplers.

Heat transfer fluid temperatures can approach 200°F (93C). Use gloves when handling hot couplers and working around the unit's hot surfaces.

2.4 Ducting

The Phoenix FireBird TX 80 can be ducted at the inlet, the outlet or both. The Phoenix FireBird TX 80 comes equipped with a snap ring on the outlet that accommodates 14" lay-flat duct. By adding the optional ductable filter box assembly, 16" flex duct can be used on the inlet. When ducting the TX 80, care must be taken to ensure airflow is not choked off due to kinks or sharp bends in the duct.

3 Maintenance

3.1 Cleaning

Coils should be checked periodically to ensure they are free of dirt and debris. Remove debris from coil with compressed air (preferred method). If coils become contaminated, they can be washed down with water and blown dry with compressed air.

If the Phoenix FireBird TX 80 is operated in dirty environments, the optional air filter kit should be installed on the intake of the machine.

4 Service

Servicing the FireBird TX 80 with its high voltage circuitry presents a health hazard which could result in death, serious bodily injury, and/or property damage. Only qualified service people should service this unit.

Do not operate the unit without all panels in place.

4.1 Technical Description

The Phoenix FireBird TX 80 uses a high efficiency heat transfer coil and high volume impeller to transfer and deliver heat to the structure. The system is designed to operate with hydronic heating module that use a low-pressure, open fluid loop distribution system with an atmospherically vented fluid reservoir. A hydronic heating module warms the heat transfer fluid. This heated fluid is pumped through a distribution system loop, passing through heat exchangers in remote locations. By providing a clean heat source, the system eliminates the need to draw in outside air, minimizing energy costs.

4.2 Troubleshooting

Blower not running

1. Unit unplugged, no power to inlet receptacle
2. Power switch not working or thermostat not calling for heat
3. Wiring fault inside device
4. Defective blower motor or capacitor

Blower running but no heat

1. Airflow restricted at inlet, outlet or fouled coil
2. Heating source not operating

5 Options and Accessories

Accessory Part	Description
4029876	DUCTABLE FILTER BOX KIT
4021799	16" x 16" x 2" MERV-8
4028363	16" X 25' HEAVY DUTY FLEX DUCT
4024936	14" X 250' LAY FLAT DUCT

6 Wiring Diagram

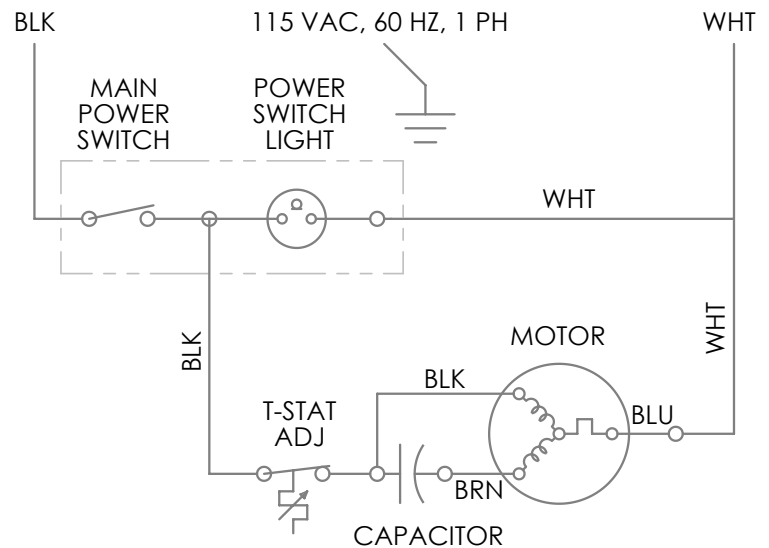

7 Service Parts

Item	Description	Service Part	Qty
1	CAPACITOR 15 MFD	4025224	1
2	HOSE CLAMP	4029411	4
3	DUST CAP	4029781	1
4	DUST PLUG	4029782	1
5	COUPLING MALE,3/4"x3/4"FNPT	4029783	1
6	COUPLING,FEMALE,3/4"x3/4"NPT	4029784	1
7	THERMOSTAT	4030411	1
8	NUT JAM 1.25-12 UNF 2B, ZP	4030193	2
9	HOSE	4029419	9.5"
10	HYDRONIC COIL	4029441	1
11	FAN,MOTORIZED IMPELLER	4029455	1
12	BULKHEAD FITTING	4030192	2
13	14" SNAP RING	4029877	1

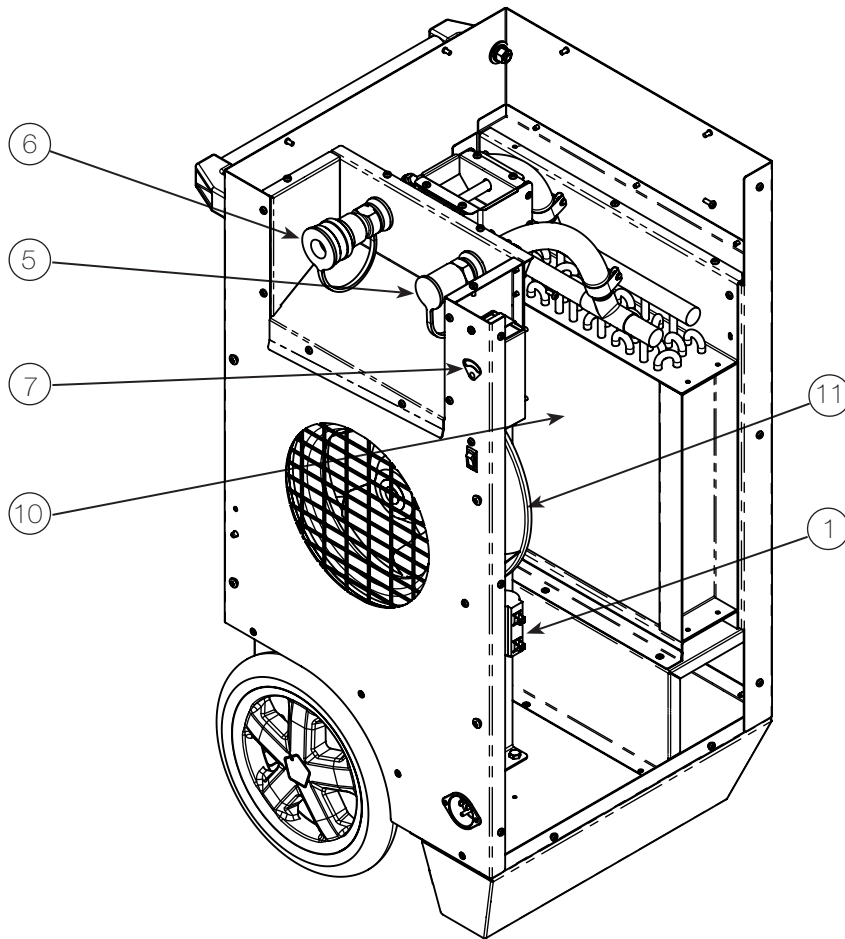

Phoenix FireBird TX 80 Limited Warranty

Warrantor:

Therma-Stor LLC
4201 Lien Rd.
Madison, WI 53704
Telephone: 1-800-533-7533

Who Is Covered: This warranty extends only to the original end-user of the Phoenix FireBird TX 80 and may not be assigned or transferred.

One Year Warranty: Therma-Stor LLC warrants that, for one (1) year the Phoenix FireBird TX 80 will operate free from any defects in materials and workmanship, or Therma-Stor LLC will, at its option, repair or replace the defective part(s), free of any charge.

End-User Responsibilities: Warranty service must be performed by a Servicer authorized by Therma-Stor LLC. If the end-user is unable to locate or obtain warranty service from an authorized Servicer, the end-user should call Therma-Stor LLC at the above number and ask for the Therma-Stor Service Department., which will then arrange for covered warranty service. Warranty service will be performed during normal working hours.

The end-user must present proof of purchase (lease) upon request, by use of the warranty card or other reasonable and reliable means. The end-user is responsible for normal care. This warranty does not cover any defect, malfunction, etc. resulting from misuse, abuse, lack of normal care, corrosion, freezing, tampering, modification, unauthorized or improper repair or installation, accident, acts of nature or any other cause beyond Therma-Stor LLC' reasonable control.

Limitations and Exclusions: If any Phoenix FireBird TX 80 part is repaired or replaced, the new part shall be warranted for only the remainder of the original warranty period applicable thereto (but all warranty periods will be extended by the period of time, if any, that the Phoenix FireBird TX 80 Desiccant Dehumidifier is out of service while awaiting covered warranty service).

UPON THE EXPIRATION OF THE WRITTEN WARRANTY APPLICABLE TO THE PHOENIX FIREBIRD TX 80 OR ANY PART THEREOF, ALL OTHER WARRANTIES IMPLIED BY LAW, INCLUDING MERCHANTABILITY AND FITNESS FOR A PARTICULAR PURPOSE, SHALL ALSO EXPIRE. ALL WARRANTIES MADE BY THERMA-STOR LLC ARE SET FORTH HEREIN, AND NO CLAIM MAY BE MADE AGAINST THERMA-STOR LLC BASED ON ANY ORAL WARRANTY. IN NO EVENT SHALL THERMA-STOR LLC, IN CONNECTION WITH THE SALE, INSTALLATION, USE, REPAIR OR REPLACEMENT OF ANY PHOENIX FIREBIRD TX 80 OR PART THEREOF BE LIABLE UNDER ANY LEGAL THEORY FOR ANY SPECIAL, INDIRECT OR CONSEQUENTIAL DAMAGES INCLUDING WITHOUT LIMITATION WATER DAMAGE (THE END-USER SHOULD TAKE PRECAUTIONS AGAINST SAME), LOST PROFITS, DELAY, OR LOSS OF USE OR DAMAGE TO ANY REAL OR PERSONAL PROPERTY.

Some states do not allow limitations on how long an implied warranty lasts, and some do not allow the exclusion or limitation of incidental or consequential damages, so one or both of these limitation may not apply to you.

Legal Rights: This warranty gives you specific legal rights, and you may also have other rights which vary from state to state.



006 04/17/08 DOWFROST* HD 50 HEAT TRANSFER FLUID, DYED

PRODUCT NAME: DOWFROST* HD 50 HEAT TRANSFER FLUID, DYED
MSDS NUMBER: DW20894
DATE ISSUED: 12/10/2007
SUPERSEDES: 08/03/2004
ISSUED BY: 008360

Material Safety Data Sheet

The Dow Chemical Company encourages and expects you to read and understand the entire (M)SDS, as there is important information throughout the document. We expect you to follow the precautions identified in this document unless your use conditions would necessitate other appropriate methods or actions.

1. Product and Company Identification

Product Name
DOWFROST* HD 50 HEAT TRANSFER FLUID, DYED

COMPANY IDENTIFICATION
The Dow Chemical Company
2030 Willard H. Dow Center
Midland, MI 48674
USA

Customer Information Number: 800-258-2436

EMERGENCY TELEPHONE NUMBER
24-Hour Emergency Contact: 989-636-4400
Local Emergency Contact: 989-636-4400

2. Hazards Identification

Emergency Overview
Color: Yellow
Physical State: Liquid
Odor: Characteristic
Hazards of product:
No significant immediate hazards for emergency response are known.

OSHA Hazard Communication Standard
This product is not a "Hazardous Chemical" as defined by the OSHA Hazard Communication Standard, 29 CFR 1910.1200.

Potential Health Effects

Eye Contact: May cause slight temporary eye irritation. Corneal injury is unlikely.

Skin Contact: Prolonged contact is essentially nonirritating to skin. Repeated contact may cause flaking and softening of skin.

Skin Absorption: Prolonged skin contact is unlikely to result in absorption of harmful amounts.

Inhalation: At room temperature, exposure to vapor is minimal due to low volatility. Mist may cause irritation of upper respiratory tract (nose and throat).

Ingestion: Very low toxicity if swallowed. Harmful effects not anticipated from swallowing small amounts.

Effects of Repeated Exposure: In rare cases, repeated excessive exposure to propylene glycol may cause central nervous system effects.

3. Composition Information

Component	CAS #	Amount
Propylene glycol	57-55-6	> 48.0 - < 54.0 %
Water	7732-18-5	< 50.0 %
Dipotassium hydrogen phosphate	7758-11-4	< 3.0 %

4. First-aid measures

Eye Contact: Flush eyes thoroughly with water for several minutes. Remove contact lenses after the initial 1-2 minutes and continue flushing for several additional minutes. If effects occur, consult a physician, preferably an ophthalmologist.

Skin Contact: Wash skin with plenty of water.

Inhalation: Move person to fresh air; if effects occur, consult a physician.

Ingestion: No emergency medical treatment necessary.

Notes to Physician: No specific antidote. Treatment of exposure should be directed at the control of symptoms and the clinical condition of the patient.

5. Fire Fighting Measures

Extinguishing Media: To extinguish combustible residues of this product use water fog, carbon dioxide, dry chemical or foam.

Fire Fighting Procedures: Keep people away. Isolate fire and deny unnecessary entry. Use water spray to cool fire exposed containers and fire affected zone until fire is out and danger of reignition has passed. To extinguish combustible residues of this product use water fog, carbon dioxide, dry chemical or foam.

Special Protective Equipment for Firefighters: Wear positive-pressure self-contained breathing apparatus (SCBA) and protective fire fighting clothing (includes fire fighting helmet, coat, trousers, boots, and gloves). If protective equipment is not available or not used, fight fire from a protected location or safe distance.

Unusual Fire and Explosion Hazards: This material will not burn until the water has evaporated. Residue can burn.

Hazardous Combustion Products: Under fire conditions some components of this product may decompose. The smoke may contain unidentified toxic and/or irritating compounds. Combustion products may include and are not limited to: Carbon monoxide. Carbon dioxide.

6. Accidental Release Measures

Steps to be Taken if Material is Released or Spilled: Small spills: Absorb with materials such as: Cat litter. Sawdust. Vermiculite. Zorb-all. Collect in suitable and properly labeled containers. Large spills: Dike area to contain spill. See Section 13, Disposal Considerations, for additional information. Personal Precautions: Keep unnecessary and unprotected personnel from entering the area. Use appropriate safety equipment. For additional information, refer to Section 8, Exposure Controls and Personal Protection.

Environmental Precautions: Prevent from entering into soil, ditches, sewers, waterways and/or groundwater. See Section 12, Ecological Information.

7. Handling and Storage

Handling

General Handling: No special precautions required. Spills of these organic materials on hot fibrous insulations may lead to lowering of the autoignition temperatures possibly resulting in spontaneous combustion. See Section 8, EXPOSURE CONTROLS AND PERSONAL PROTECTION.

Storage

Do not store in: Galvanized steel. Opened or unlabeled containers. Store in the following material(s): Carbon steel. Stainless steel. Store in original unopened container. See Section 10 for more specific information. Additional storage and handling information on this product may be obtained by calling your Dow sales or customer service contact.

8. Exposure Controls / Personal Protection

Exposure Limits

Component	List	Type	Value
Propylene glycol	WEEL	TWA Aerosol.	10 mg/m3

Personal Protection

Eye/Face Protection: Use safety glasses.

Skin Protection: Wear clean, body-covering clothing.

Hand protection: Use gloves chemically resistant to this material when prolonged or frequently repeated contact could occur. Examples of preferred glove barrier materials include: Butyl rubber. Natural rubber ("latex"). Neoprene. Nitrile/butadiene rubber ("nitrile" or "NBR"). Polyethylene. Ethyl vinyl alcohol laminate ("EVAL"). Polyvinyl alcohol ("PVA"). Polyvinyl chloride ("PVC" or "vinyl"). NOTICE: The selection of a specific glove for a particular application and duration of use in a workplace should also take into account all relevant workplace factors such as, but not limited to: Other chemicals which may be handled, physical requirements (cut/puncture protection, dexterity, thermal protection), potential body reactions to glove materials, as well as the instructions/specifications provided by the glove supplier.

Respiratory Protection: Respiratory protection should be worn when there is a potential to exceed the exposure limit requirements or guidelines. If there are no applicable exposure limit requirements or guidelines, wear respiratory protection when adverse effects, such as respiratory irritation or discomfort have been experienced, or where indicated by your risk assessment process. In misty atmospheres, use an approved particulate respirator. The following should be effective types of air-purifying respirators: Organic vapor cartridge with a particulate pre-filter.

Ingestion: Use good personal hygiene. Do not consume or store food in the work area. Wash hands before smoking or eating.

Engineering Controls

Ventilation: Use local exhaust ventilation, or other engineering controls to maintain airborne levels below exposure limit requirements or guidelines. If there are no applicable exposure limit requirements or guidelines, general ventilation should be sufficient for most operations. Local exhaust ventilation may be necessary for some operations.

9. Physical and Chemical Properties

Physical State	Liquid
Color	Yellow or Orange
Odor	Characteristic
Flash Point - Closed Cup	Not applicable, water boils off
Flammable Limits In Air	Lower: 2.6 %(V) Literature Propylene glycol Upper: 12.5 %(V) Literature Propylene glycol
Autoignition Temperature	371 deg C (700 deg F) Literature Propylene glycol
Vapor Pressure	15.5 mmHg g 20 deg C Literature
Boiling Point (760 mmHg)	104 deg C (219 deg F) Literature .
Vapor Density (air = 1)	>1.0 Literature
Specific Gravity (H2O = 1)	1.06 20 0C/20 deg C Literature
Freezing Point	-33.8 deg C (-28.8 deg F) Literature
Melting Point	Not applicable to liquids
Solubility in Water (by weight)	100 %Literature
pH	9.5 Literature
Kinematic Viscosity	6.3 cSt Literature

10. Stability and Reactivity

Stability/Instability

Thermally stable at recommended temperatures and pressures.

Conditions to Avoid: Some components of this product can decompose at elevated temperatures. Generation of gas during decomposition can cause pressure in closed systems.

Incompatible Materials: Avoid contact with: Strong acids. Strong bases. Strong oxidizers.

Hazardous Polymerization

Will not occur.

Thermal Decomposition

Decomposition products depend upon temperature, air supply and the presence of other materials.

11. Toxicological Information

Acute Toxicity

Ingestion

LD50, Rat, female 20,300 mg/kg

Skin Absorption

For similar material(s): LD50, Rabbit > 10,000 mg/kg

Sensitization

Skin

For the major component(s): Did not cause allergic skin reactions when tested in humans.

Repeated Dose Toxicity

In rare cases, repeated excessive exposure to propylene glycol may cause central nervous system effects.

Chronic Toxicity and Carcinogenicity

Similar formulations did not cause cancer in laboratory animals.

Developmental Toxicity

For the major component(s): Did not cause birth defects or any other fetal effects in laboratory animals.

Reproductive Toxicity

For the major component(s): In animal studies, did not interfere with reproduction. In animal studies, did not interfere with fertility.

Genetic Toxicology

In vitro genetic toxicity studies were negative. For the major component(s): Animal genetic toxicity studies were negative.

12. Ecological Information

CHEMICAL FATE

Movement & Partitioning

For the major component(s): Bioconcentration potential is low (BCF less than 100 or log Pow less than 3). Potential for mobility in soil is very high (Koc between 0 and 50).

Persistence and Degradability

For the major component(s): Material is readily biodegradable. Passes OECD test(s) for ready biodegradability.

ECOTOXICITY

For the major component(s): Material is practically non-toxic to aquatic organisms on an acute basis (LC50/EC50 >100 mg/L in the most sensitive species tested).

13. Disposal Considerations

DO NOT DUMP INTO ANY SEWERS, ON THE GROUND, OR INTO ANY BODY OF WATER. All disposal practices must be in compliance with all Federal, State/Provincial and local laws and regulations. Regulations may vary in different locations. Waste characterizations and compliance with applicable laws are the responsibility solely of the waste generator. DOW HAS NO CONTROL OVER THE MANAGEMENT PRACTICES OR MANUFACTURING PROCESSES OF PARTIES HANDLING OR USING THIS MATERIAL. THE INFORMATION PRESENTED HERE PERTAINS ONLY TO THE PRODUCT AS SHIPPED IN ITS INTENDED CONDITION AS DESCRIBED IN MSDS SECTION: Composition Information. FOR UNUSED & UNCONTAMINATED PRODUCT, the preferred options include sending to a licensed, permitted: Recycler. Reclaimer. Incinerator or other thermal destruction device. As a service to its customers, Dow can provide names of information resources to help identify waste management companies and other facilities which recycle, reprocess or manage chemicals or plastics, and that manage used drums. Telephone Dow's Customer Information Group at 1-800-258-2436 or 1-989-832-1556 (U.S.), or 1-800-331-6451 (Canada) for further details.

14. Transport Information

DOT Non-Bulk
NOT REGULATED

DOT Bulk
NOT REGULATED

IMDG
NOT REGULATED

ICAO/IATA
NOT REGULATED

This information is not intended to convey all specific regulatory or operational requirements/information relating to this product. Additional transportation system information can be obtained through an authorized sales or customer service representative. It is the responsibility of the transporting organization to follow all applicable laws, regulations and rules relating to the transportation of the material.

15. Regulatory Information

OSHA Hazard Communication Standard

This product is not a "Hazardous Chemical" as defined by the OSHA Hazard Communication Standard, 29 CFR 1910.1200.

Superfund Amendments and Reauthorization Act of 1986 Title III (Emergency Planning and Community Right-to-Know Act of 1986) Sections 311 and 312

Immediate (Acute) Health Hazard	No
Delayed (Chronic) Health Hazard	No
Fire Hazard	No
Reactive Hazard	No
Sudden Release of Pressure Hazard	No

Superfund Amendments and Reauthorization Act of 1986 Title III (Emergency Planning and Community Right-to-Know Act of 1986) Section 313

To the best of our knowledge, this product does not contain chemicals at levels which require reporting under this statute.

Pennsylvania (Worker and Community Right-To-Know Act): Pennsylvania Hazardous Substances List and/or Pennsylvania Environmental Hazardous Substance List: The following product components are cited in the Pennsylvania Hazardous Substance List and/or the Pennsylvania Environmental Substance List, and are present at levels which require reporting.

Component	CAS #	Amount
Propylene glycol	57-55-6	> 48.0 - < 54.0 %

Pennsylvania (Worker and Community Right-To-Know Act): Pennsylvania Special Hazardous Substances List:

To the best of our knowledge, this product does not contain chemicals at levels which require reporting under this statute.

California Proposition 65 (Safe Drinking Water and Toxic Enforcement Act of 1986)

This product contains no listed substances known to the State of California to cause cancer, birth defects or other reproductive harm, at levels which would require a warning under the statute.

Toxic Substances Control Act (TSCA)

All components of this product are on the TSCA Inventory or are exempt from TSCA Inventory requirements under 40 CFR 720.30

CEPA - Domestic Substances List (DSL)

This product contains one or more substances which are not listed on the Canadian Domestic Substances List (DSL). Contact your Dow representative for more information.

16. Other Information

Hazard Rating System

NFPA	Health	Fire	Reactivity
	0	0	0

Recommended Uses and Restrictions

Intended as a heat transfer fluid for closed-loop systems. Dow recommends that you use this product in a manner consistent with the listed use. If your intended use is not consistent with Dow's stated use, please contact Dow's Customer Information Group.

Legend

N/A	Not available
W/W	Weight/Weight
OEL	Occupational Exposure Limit
STEL	Short Term Exposure Limit
TWA	Time Weighted Average
ACGIH	American Conference of Governmental Industrial Hygienists, Inc.
DOW IHG	Dow Industrial Hygiene Guideline
WEEL	Workplace Environmental Exposure Level

HAZ_DES Hazard Designation
Action Level A value set by OSHA that is lower than the PEL which will trigger the need for activities such as exposure monitoring and medical surveillance if exceeded.

----- FOR ADDITIONAL INFORMATION -----
CONTACT: MSDS COORDINATOR UNIVAR USA INC.
DURING BUSINESS HOURS, PACIFIC TIME (425) 889-3400
----- NOTICE -----

***** UNIVAR USA INC ("UNIVAR") EXPRESSLY DISCLAIMS

ALL EXPRESS OR IMPLIED WARRANTIES OF MERCHANTABILITY AND FITNESS FOR A

PARTICULAR PURPOSE, WITH RESPECT TO THE PRODUCT OR INFORMATION PROVIDED HEREIN,

AND SHALL UNDER NO CIRCUMSTANCES BE LIABLE FOR INCIDENTAL OR CONSEQUENTIAL DAMAGES.**

DO NOT USE INGREDIENT INFORMATION AND/OR INGREDIENT PERCENTAGES IN THIS MSDS AS A PRODUCT SPECIFICATION. FOR PRODUCT SPECIFICATION INFORMATION REFER TO A PRODUCT SPECIFICATION SHEET AND/OR A CERTIFICATE OF ANALYSIS. THESE CAN BE OBTAINED FROM YOUR LOCAL UNIVAR SALES OFFICE.

ALL INFORMATION APPEARING HEREIN IS BASED UPON DATA OBTAINED FROM THE MANUFACTURER AND/OR RECOGNIZED TECHNICAL SOURCES. WHILE THE INFORMATION IS BELIEVED TO BE ACCURATE, UNIVAR MAKES NO REPRESENTATIONS AS TO ITS ACCURACY OR SUFFICIENCY. CONDITIONS OF USE ARE BEYOND UNIVARS CONTROL AND THEREFORE USERS ARE RESPONSIBLE TO VERIFY THIS DATA UNDER THEIR OWN OPERATING CONDITIONS TO DETERMINE WHETHER THE PRODUCT IS SUITABLE FOR THEIR PARTICULAR PURPOSES AND THEY ASSUME ALL RISKS OF THEIR USE, HANDLING, AND DISPOSAL OF THE PRODUCT, OR FROM THE PUBLICATION OR USE OF, OR RELIANCE UPON, INFORMATION CONTAINED HEREIN. THIS INFORMATION RELATES ONLY TO THE PRODUCT DESIGNATED HEREIN, AND DOES NOT RELATE TO ITS USE IN COMBINATION WITH ANY OTHER MATERIAL OR IN ANY OTHER PROCESS.

* * * E N D O F M S D S * * *